

4.4 Digital output module ICSO 08 R1, 8 relay outputs 2 A Outputs and CS31 system bus interface electrically isolated

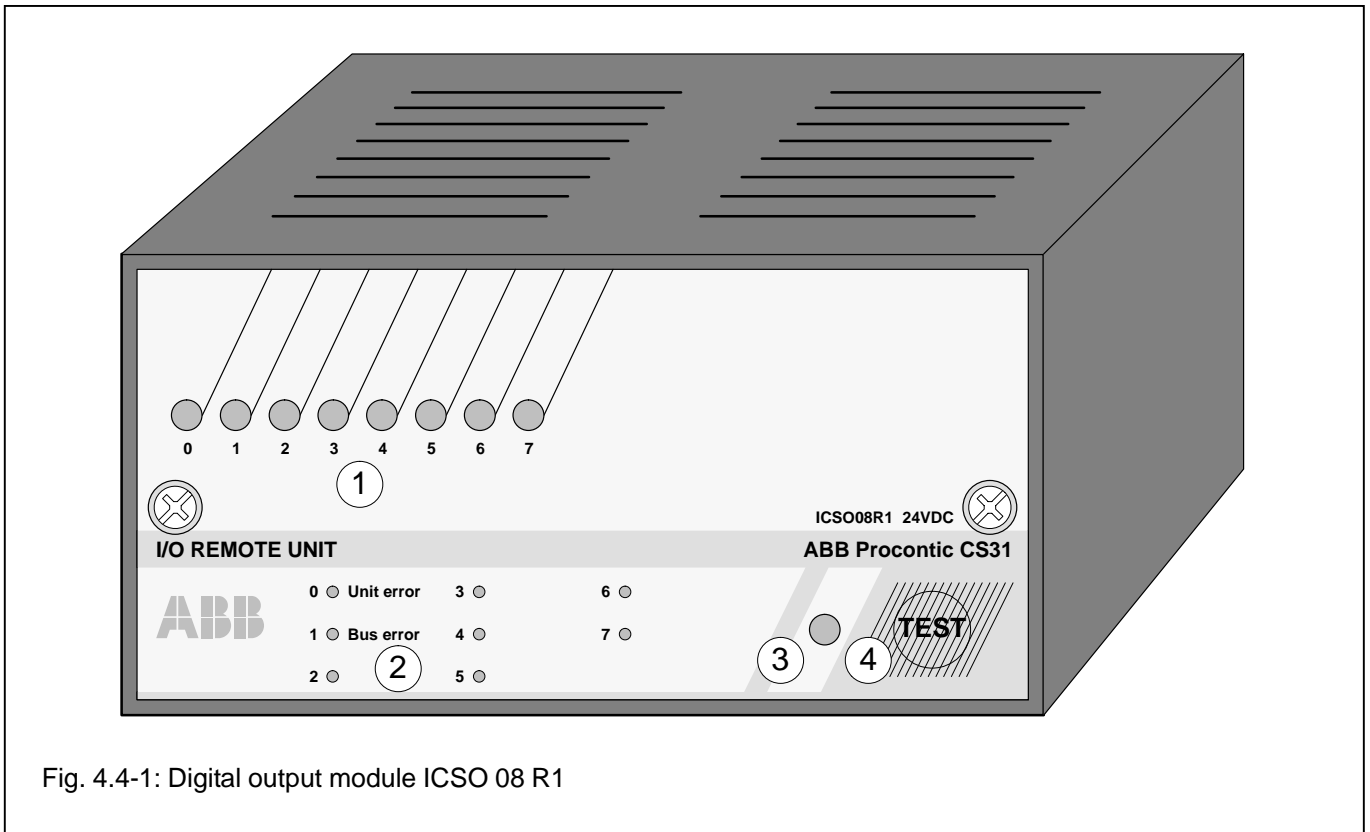

Fig. 4.4-1: Digital output module ICSO 08 R1

Contents

Intended purpose	4.4-1
Display and operating elements on the front panel	4.4-1
Electrical connection	4.4-1
Addressing	4.4-4
I/O configuration	4.4-4
Normal operation	4.4-4
Diagnosis and displays	4.4-4
Technical data	4.4-5
Dimensions for installation	4.4-6

Intended purpose

The digital output module ICSO 08 R1 is used as a remote module on the CS31 system bus. It contains 8 relay output channels with the following features:

- The relay outputs
 - are electrically isolated (from each other and from the rest of the module and
 - can be loaded with 2 A.

The module is available for supply voltages of 24 V DC and 230 V AC. For electrical connection, it has to be mounted on a plug-in base ECZ.

The CS31 system bus interface is electrically isolated from the rest of the module.

The module offers a number of diagnosis functions (see chapter "Diagnosis and displays").

Display and operating elements on the front panel

- ① 8 yellow LEDs to indicate the signal status of the outputs or for displaying error and diagnosis data
- ② List of diagnosis information concerning the LEDs when they are used for diagnosis display
- ③ Red LED for error message
- ④ Test button

Electrical connection

The module has to be mounted on the plug-in base ECZ and then fastened with two screws. The plug-in base has a mechanical coding which prevents that a module can be plugged-in with another supply voltage than set on the ECZ. Before mounting the input module, the mechanical coding has to be set to the correct supply voltage.

The following three figures show the electrical connection of the output module.

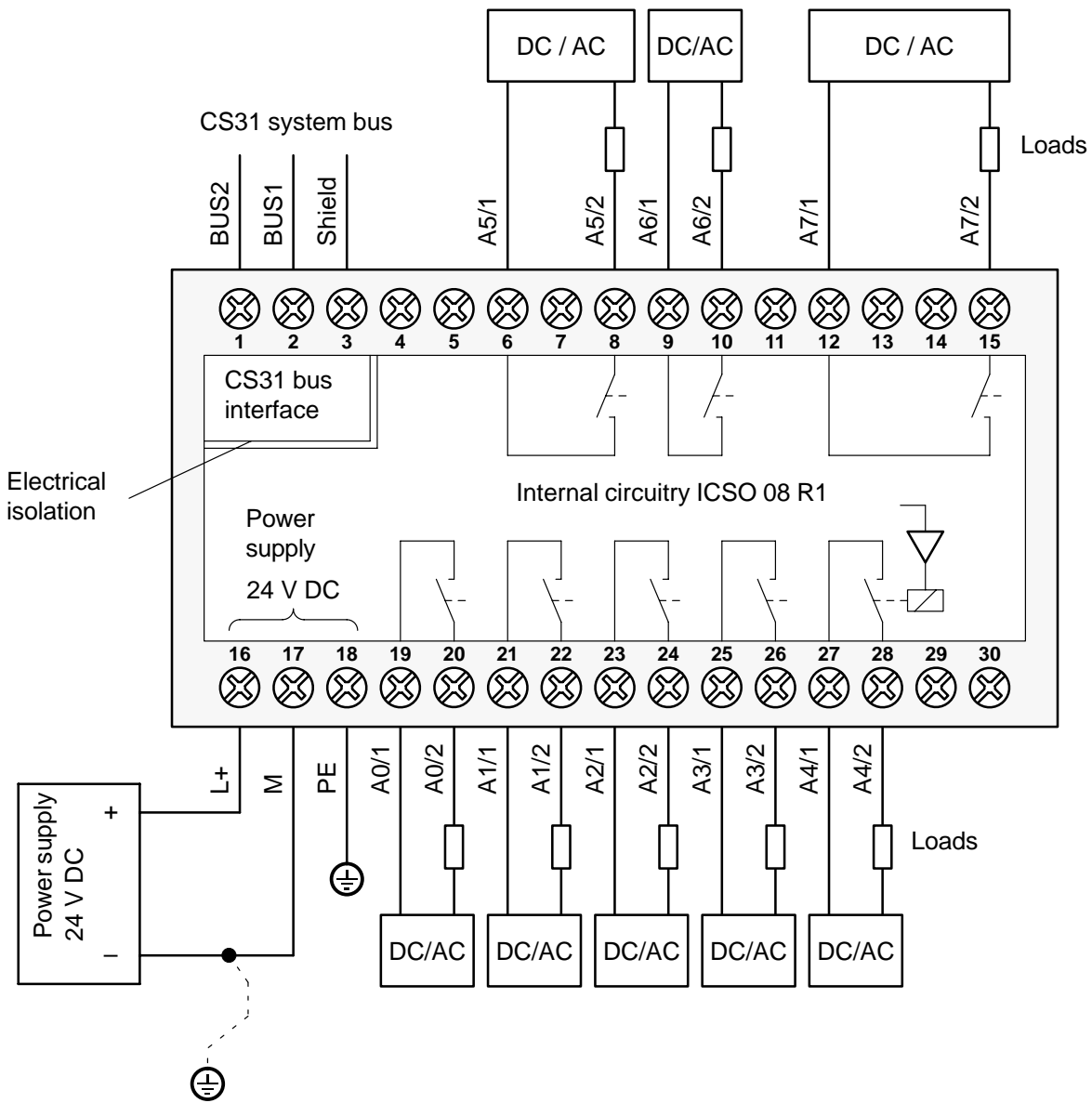

Important: The supply voltage must be included in the earthing concept of the control system (e.g. earthing of the minus pole).

Addressing and I/O configuration are set with this DIL switch.

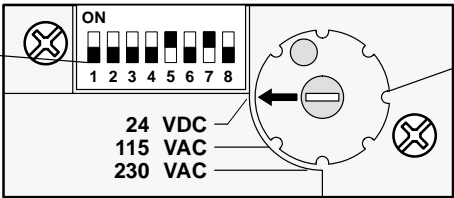

The supply voltage is set with this mechanical coding.

Fig. 4.4-2: Electrical connection of the digital output module ICSO 08 R1, supply voltage 24 V DC

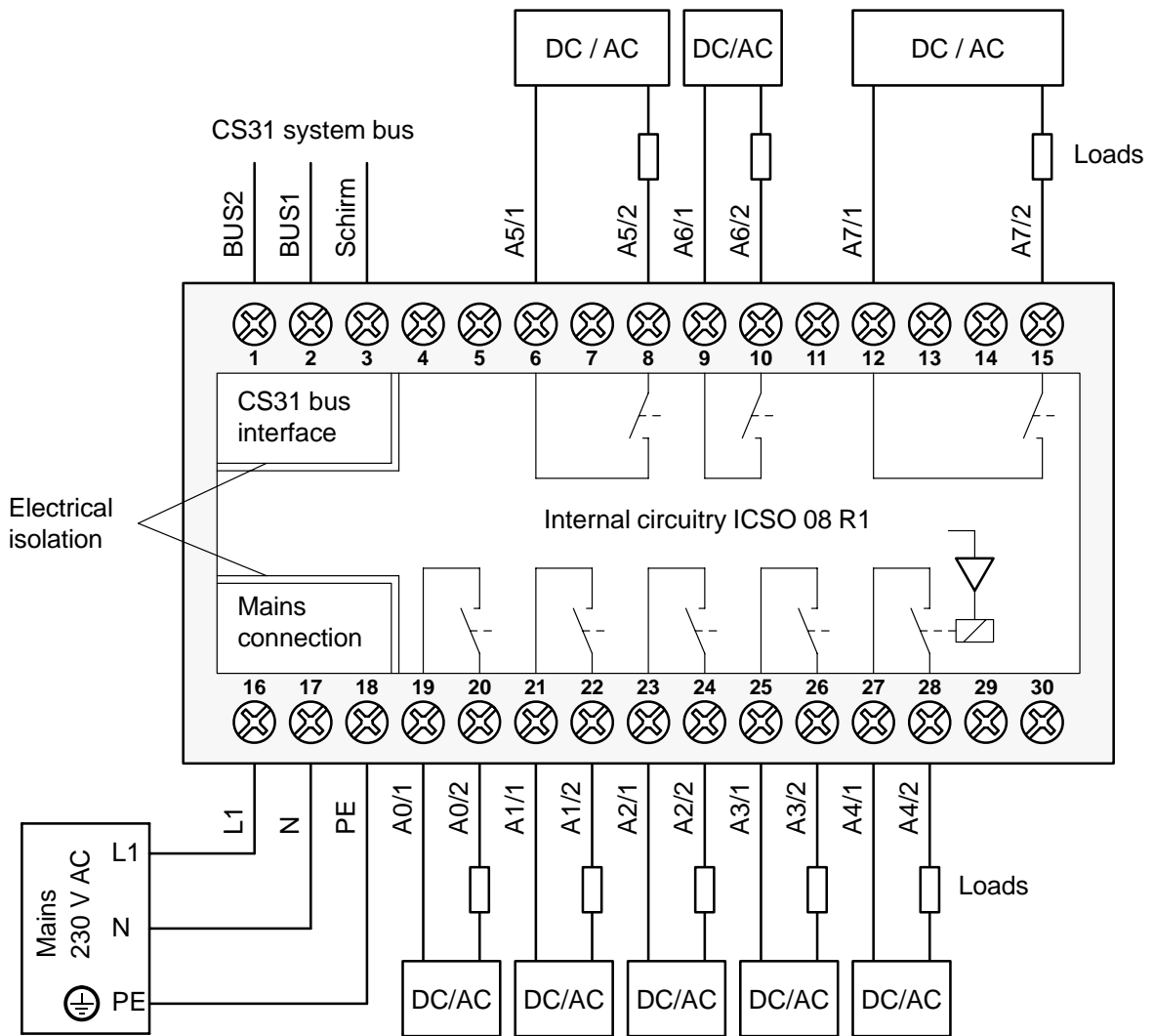

Addressing and I/O configuration are set with this DIL switch.

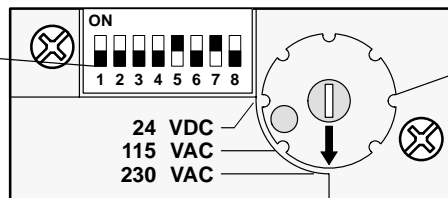

The supply voltage is set with this mechanical coding.

Fig. 4.4-3: Electrical connection of the digital output module ICSO 08 R1, supply voltage 230 V AC

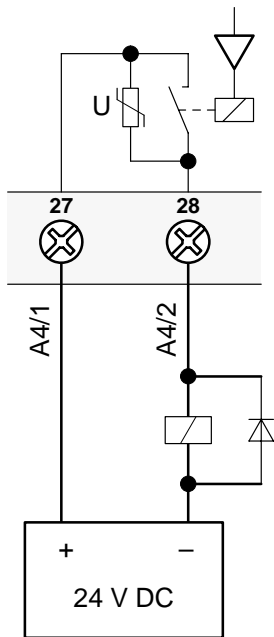

In order to suppress switching sparks when switching inductive AC loads, the relay contacts are equipped with varistors.

If, however, **inductive DC loads** are switched, **one free-wheeling diode must be mounted in parallel to each of the loads** for demagnetization.

Fig. 4.4-4: Electrical connection of inductive DC loads

Addressing

An address must be set for each module to enable the basic unit to correctly access the outputs.

The address setting is accomplished with the DIL switch on the plug-in base ECZ. When using the basic units 07 KR 91 and 07 KT 9x as bus masters, the following address assignments are valid:

Basic unit	07 KR 91 / 07 KT 9x	
DIL switch No. 8 on the ECZ	OFF (recommended)	ON
Channel		
A0	A xx,00	A xx,08
A1	A xx,01	A xx,09
A2	A xx,02	A xx,10
A3	A xx,03	A xx,11
A4	A xx,04	A xx,12
A5	A xx,05	A xx,13
A6	A xx,06	A xx,14
A7	A xx,07	A xx,15
xx: Group number of the address, set on the DIL switch of the plug-in base with the switches 2...7. Recommended addresses with 07 KR 91 / 07 KT 9x as bus masters: 08, 10, 12...60 (even-numbered addresses)		

A detailed description about "Addressing" can be found in the chapter "Addressing" of the basic units and couplers.

The module uses 8 outputs on the CS31 system bus.

I/O configuration

An I/O configuration is not necessary.

Normal operation

- After power ON the module initializes automatically. During this period the red LED (3) flashes.
- After initialization the red LED (3) goes out, if the bus runs correctly and if the module has detected no error.
- The 8 yellow LEDs (1) indicate the signal statuses of the channels A0...A7.

Diagnosis and displays

Diagnosis functions:

- Error inside the module
- Error on the CS31 system bus

If one of these errors occurs, the red LED (3) lights up.

Using the test button (4) and the LEDs (1), diagnosis information can be achieved directly at the module.

By pressing the test button the first time, the channel **A0** is selected: LED0 flashes. After releasing the test button, the diagnosis information of this channel is displayed with the 8 yellow LEDs for a period of ca. 3 seconds.

The ON status of the LEDs means:

- 0 Error inside the module (Unit error)
- 1 Error on the CS31 system bus (Bus error)
- 2...7 not used

The meaning of the LEDs (2) is also printed on the front panel of the module in English.

With every further pushing and releasing the test button, the described procedure repeats for the other channels.

After calling up the last channel (A7), a lamp test (LED test) is performed when the test button is pushed again. All 8 LEDs must light up.

After releasing the test button, the 8 LEDs show the setting of the DIL switches of the plug-in base for a period of ca. 5 seconds. LED0 shows switch 1 (LEDs 0...7 belong to the switches 1...8).

All error messages are stored in the module. They can be deleted in the following ways:

- by pressing the test button for about 10 seconds or
- with power OFF/ON or
- via the CS31 system bus.

Diagnosis data, which can be evaluated, are also sent to the basic units and couplers which work as the bus master.

For further details see the chapter "Diagnosis" in the description of the basic units and couplers.

After finishing the diagnosis procedure, the 8 LEDs again show the signal statuses of the channels. The same is valid for the pauses between the steps of the procedure.

Technical data

General data of the module

Versions	R 1022	R0026
Rated supply voltage	24 V DC	230 V AC, 50 or 60 Hz
Max. current consumption without output loads	0.2 A	
Max. power consumption without output loads		6 VA
Max. power dissipation in the module	5 W	5 W
Max. conductor cross section of the terminals (flexible lead with wire end ferrule)	2 cores of 2.5 mm ² per terminal	
Weight	Plug-in base ECZ Module ICSO 08 R1	200 g 430 g

Technical data of the outputs

Number of outputs per module	8 relay outputs (1 make contact each)
Process supply voltage / contact voltage	max. 250 V AC
Data of the relay contacts	
Switching current	max. 2 A
Total current of the 8 outputs	max. 16 A
Switching power AC	max. 500 VA
Switching power DC	max. 60 W
Minimum switching power	0.1 mA / 0.1 V DC
Contact life cycle	
mechanical	> 3 x 10 ⁷ cycles
230 V AC, 2 A resistive load	> 1 x 10 ⁵ cycles
Protection for relay contacts when switching inductive loads	
with AC	built-in varistor
with DC	a free-wheeling diode must be circuited in parallel to the load
Signalling	1 yellow LED per channel

Mechanical data

Installation methods	on a DIN rail or fastening by screws
Mounting depth including the plug-in base and a flat DIN rail	117 mm
Dimensions of the plug-in base (see the drawing below)	
snapping onto the DIN rail	centrally between top and bottom of the plug-in base
fastening by M4 screws	102 mm x 22 mm
max. outline dimensions of the plug-in base	124 mm x 64 (+12) mm

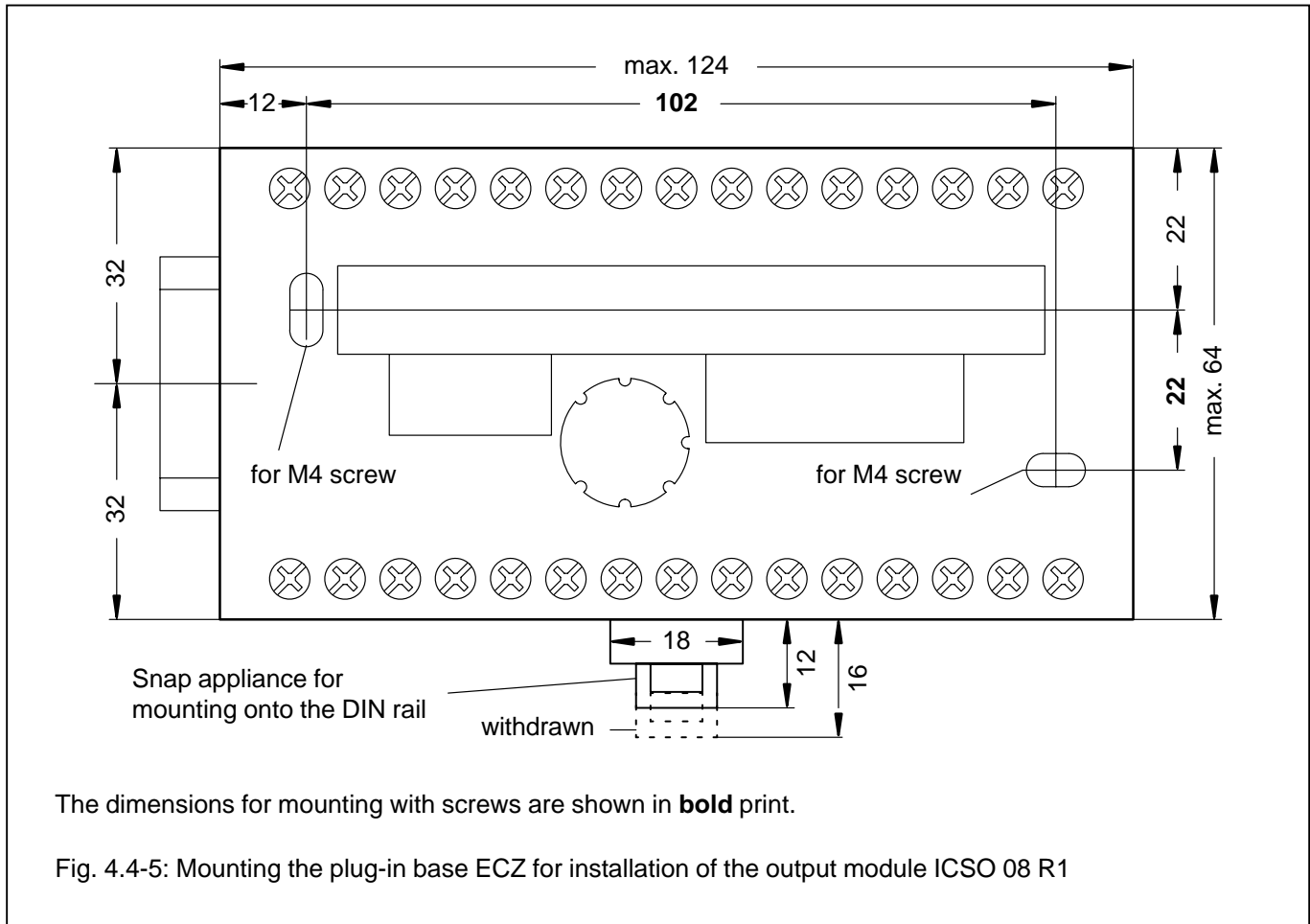

Ordering data

Order numbers	Plug-in base ECZ		FPR3700001R0001
	Module ICSO 08 R1	24 V DC	FPR3312101R1022
	Module ICSO 08 R1	230 V AC	FPR3312101R0026